

RS

Precision Cylindrical Grinding Machines

The RS series modularly designed Precision Cylindrical Grinding Machines for every application.

**Distance between centers
from 600 mm**

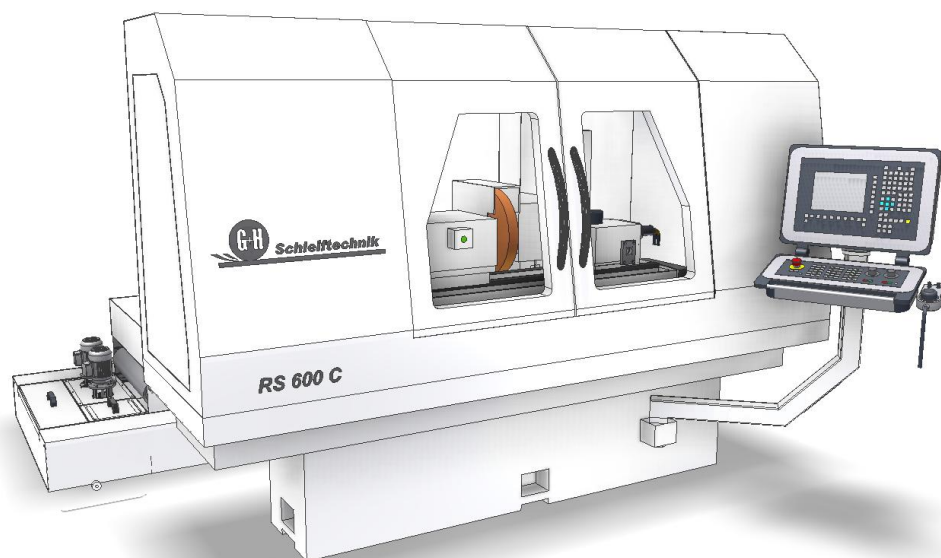

up to 6000 mm

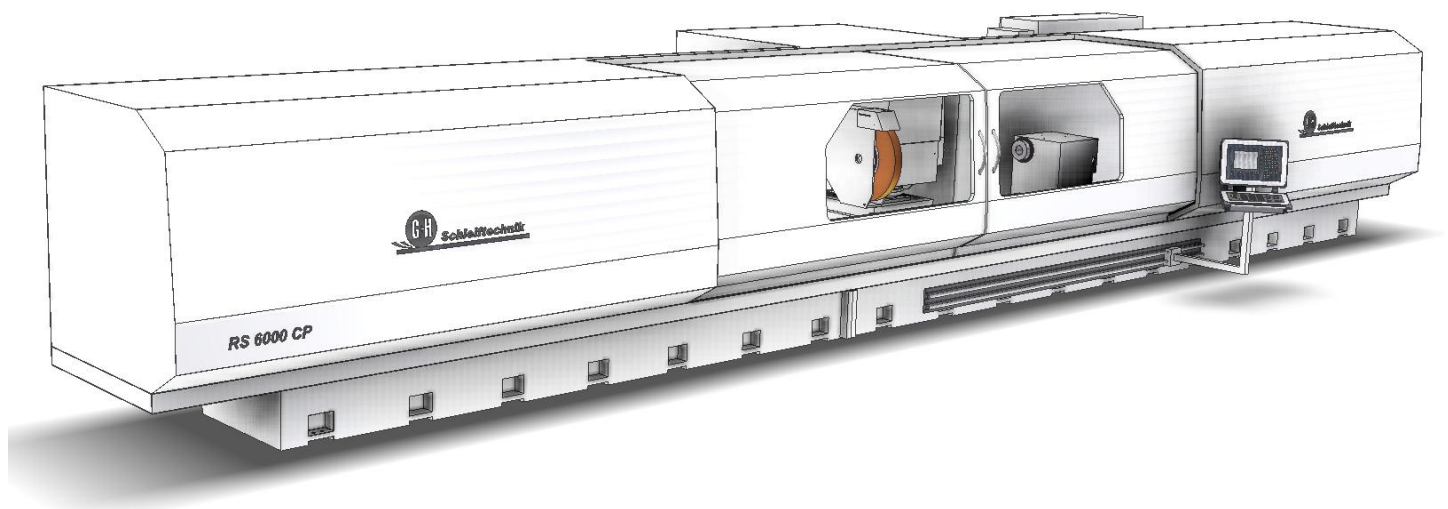

B-axis and grinding spindle arrangements

The slewing of the B-Axis is effected infinitely: Fast and accurately.
A multitude of grinding spindle arrangements is available.

Exterior grinding wheel,
left hand

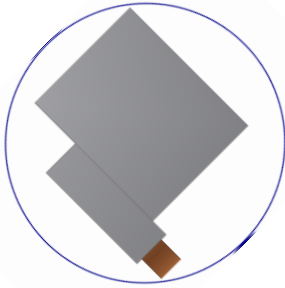

Exterior grinding wheel, left hand,
Planar grinding wheel, right hand

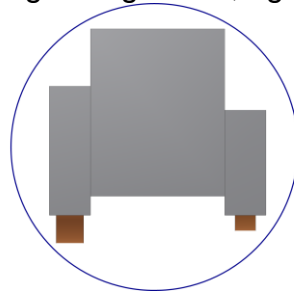

2x Exterior grinding wheel,
left hand

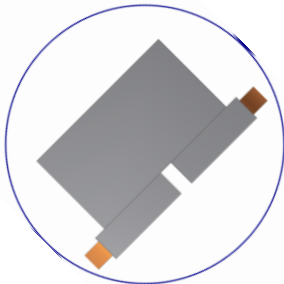
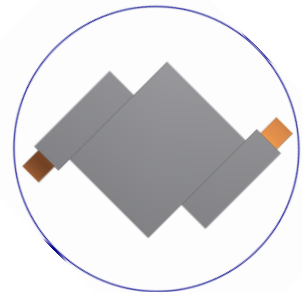

Exterior grinding wheel,
left hand
Exterior grinding wheel,
right hand

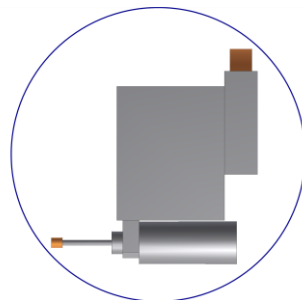
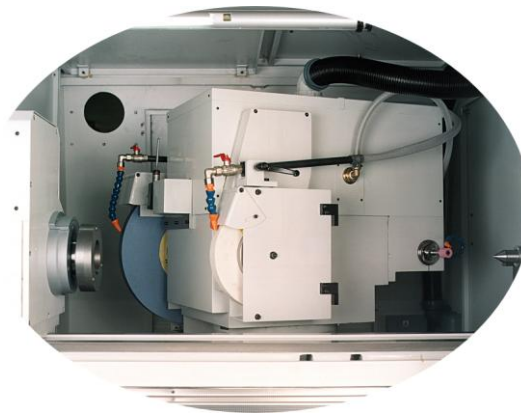

Exterior grinding wheel, left hand,
Interior grinding spindle

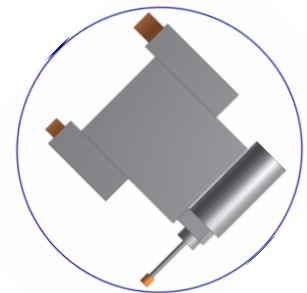

Exterior grinding wheel,
left hand,
Planar grinding wheel,
right hand,
Interior grinding spindle

Production machine

Machines which are designed for serial production can be equipped with a loading robot and in-process-dimensional control.





Control

The control is based on the well-proven SINUMERIK 840 D. The proprietary developed, highly intuitive user interface allows easy dialogue based input of all geometrical- and process data. For single production or matching all axes can be controlled with the electric hand wheel.

Virtual file cabinets

The Data of any number of workpieces, up to 100 grinding wheels and 40 dressers are stored in virtual file cabinets.



Cylindricity-error-correction

The cylindricity-error-correction for all dressable grinding wheels is effected program-controlled.



Dressing

The dressing is effected from the workpiece spindle head or from the tailstock. All dressing amounts are compensated. Other dressing devices like diamond rolls or swivel dressers can be integrated into the machine on demand. Several dressing strategies are available in the control. Using the graphic support for the profile setup process and the integrated CAD program (option), virtually any grinding wheel profile can be created conveniently and fast. The transfer of existing CAD-data is possible (option).

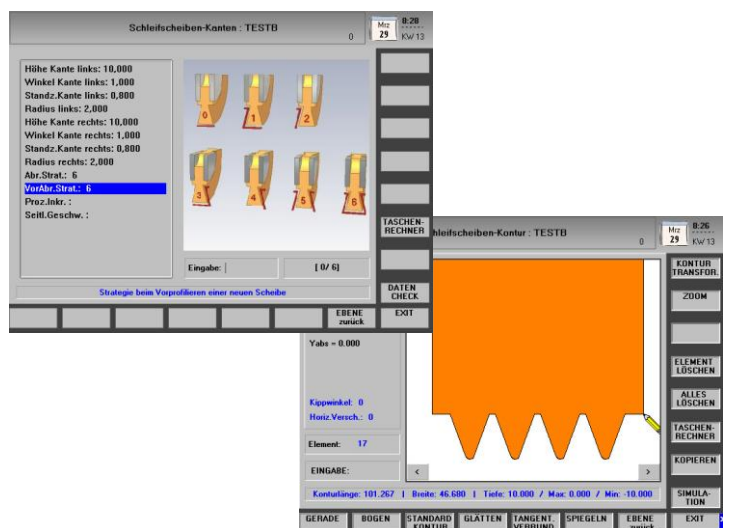

The G+H modular design

1. You choose your **basic machine**:

- Distance between centers
- Center height
- Component weight

2. You choose your individual **options**:

- Slewability of B-axis (manual or infinitely automatically)
- Number and arrangement of grinding spindles (exterior and interior grinding spindles)
- Positionar (Z-length-caliper)
- GAP-control
- In-process-dimensional control
- Controlled C-axis (non-cylindrical grinding)
- Hydrostatic guideway in X-axis (infeed axis)
- Swivel dresser, diamond roll
- Servo-controlled tailstock with pressing force programming
- Network connection
- Data back-up
- Remote maintenance

3. You combine your machine with appropriate **aggregates** like:

- Universal paper filter system
- Compact air cleaning set

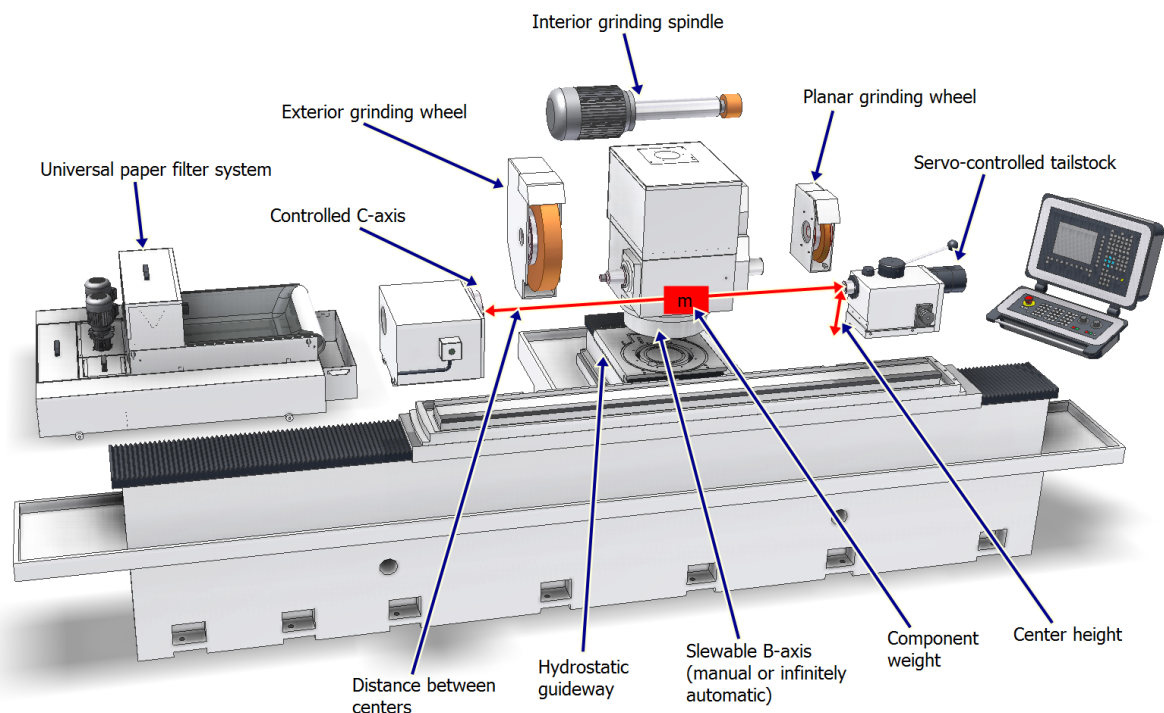

We assemble your machine following your desires!

*Please note: Options and aggregates are not exhaustive.
Some combinations can be mutually exclusive!*

Models of machines		RS 600 C	RS 1000 C		RS 600 CU	RS 1000 CU	
Distance between centers	mm	600	1000		600	1000	
Center height	mm	140	140		180 (230)	180 (230)	
Grinding length	mm	600	1000		600	1000	
Component weight between centers	kg	100	100		150	150	
Component weight, cantilever	kg	20	20		60	60	
Load during cantilever grinding	Nm	40	40		120	120	
X-AXIS = INFEEED MOVEMENT							
Infeed speed	mm/min	0,01 - 8000	0,01 - 8000		0,01 - 8000	0,01 - 8000	
Linear measurement system, internal resolution	mm	0,0005	0,0005		0,0005	0,0005	
Z-AXIS = TABLE MOVEMENT							
Table speed	mm/min	0,01 – 12000	0,01 – 12000		0,01 – 12000	0,01 – 12000	
C-AXIS = WORKPIECE SPINDLE HEAD							
Rotation speed	min ⁻¹	0 – 600	0 – 600		0 – 600	0 – 600	
Power	kW	2,0	2,0		2,0	2,0	
Chuck cone		MK 4 / KK 5	MK 4 / KK 5		MK 5 / KK 5	MK 5 / KK 5	
GRINDING SPINDLES							
Power of grinding spindle motor	kW	5,5 with water cooling	5,5 with water cooling		9	9	
Peripheral surface speed of grinding wheel	m/s	35 (50)	35 (50)		35 (50)	35 (50)	
Grinding wheel, standard	mm	400x50x127	400x50x127		500x80x203,2	500x80x203,2	
Planar grinding wheel, right hand (option)	mm	-	-		300x40x127	300x40x127	
Interior grinding spindle (option)		-	-		at customer's option	at customer's option	
TAILSTOCK							
Chuck cone		MK 4	MK 4		MK 4	MK 4	
Workpiece fixture		manual	manual		manual (hydraulic)	manual (hydraulic)	

	RS 1500 CU	RS 2000 CU		RS 1500 CM bis RS 4000 CM		RS 1500 CP bis RS 6000 CP		RS 3000 CPA bis RS 6000 CPA
	1500	2000		1500 - 4000		1500 - 6000		3000 - 6000
	180 (230)	180 (230)		230 (300)		230 (320)		400 (500)
	1500	2000		1500 – 4000		1500 – 6000		3000 - 6000
	150	150		800		2000		4000
	60	60		100		200		400
	120	120		200		600		1600
	0,01 - 8000	0,01 - 8000		0,01 - 8000		0,01 - 8000		0,01 - 8000
	0,0005	0,0005		0,0005		0,0005		0,0005
	0,01 – 12000	0,01 – 12000		0,01 – 10000		0,01 – 8000		0,01 – 8000
	0 – 600	0 – 600		0 – 300		0 – 300		0 – 200
	2,0	2,0		3,0		3,0		3,0
	MK 5 / KK 5	MK 5 / KK 5		MK 5 / KK 5		MK 6 / KK 8		ME 80 / KK 11
	9	9		11		18		18
	35 (50)	35 (50)		35 (50)		35 (50)		35 (50)
	500x80x203,2	500x80x203,2		600x80x203,2		600x80x304,8 (750x80x304,8)		600x80x304,8 (750x80x304,8)
	300x40x127	300x40x127		300x40x127		400x40x127		400x40x127
	at customer's option	at customer's option		at customer's option		at customer's option		at customer's option
	MK 4	MK 4		MK 4		MK 6		ME 80
	manual (hydraulic)	manual (hydraulic)		manual (hydraulic)		servomotor		servomotor

() Option

Technical data are subject to change without notice

Grinding processes

A multitude of grinding processes is available. For the machining of a certain workpiece, up to 26 processes can be linked.



X-plunge grinding

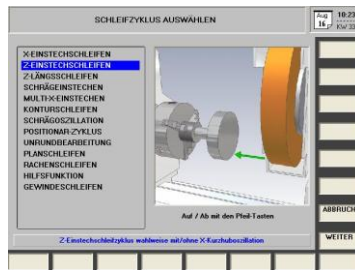

Z-plunge grinding



Z-longitudinal grinding

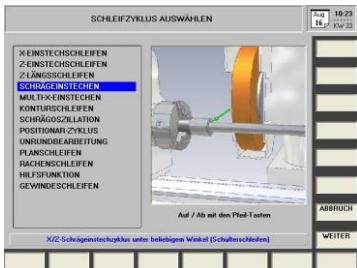

Angular approach creep feed grinding

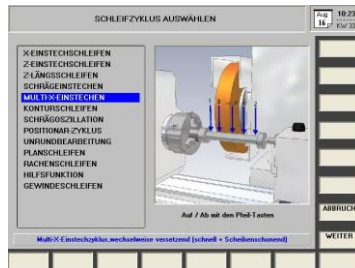

Multi-X-plunge



Contour grinding



Angular oscillation



Positionar-cycle



Non-cylindrical grinding

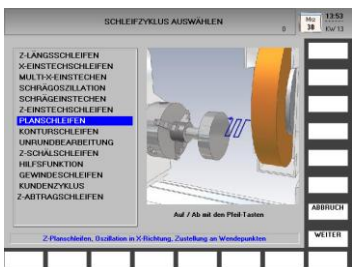

Face grinding

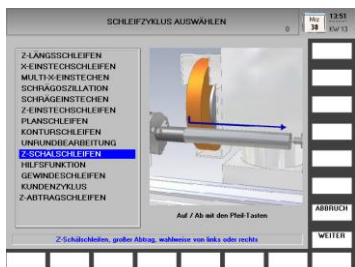

Z-peel grinding

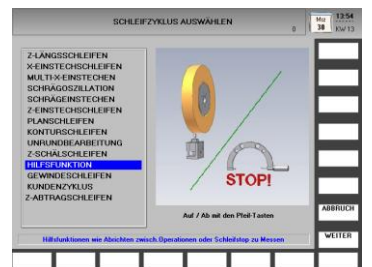

„Help“-cycle

Geibel & Hotz GmbH

PO Box 1161 • D-35311 Homberg (Ohm)
 Frankfurter Straße 102 – 104 • D-35315 Homberg (Ohm)
 Telephone (06633) 181-0 • Telefax (06633) 181-18
 E-Mail info@gh-schleiftechnik.de
 www.gh-schleiftechnik.de • www.gh-grinding.com